

5 代端板规格书

1. 产品尺寸图 Product Dimension Diagram

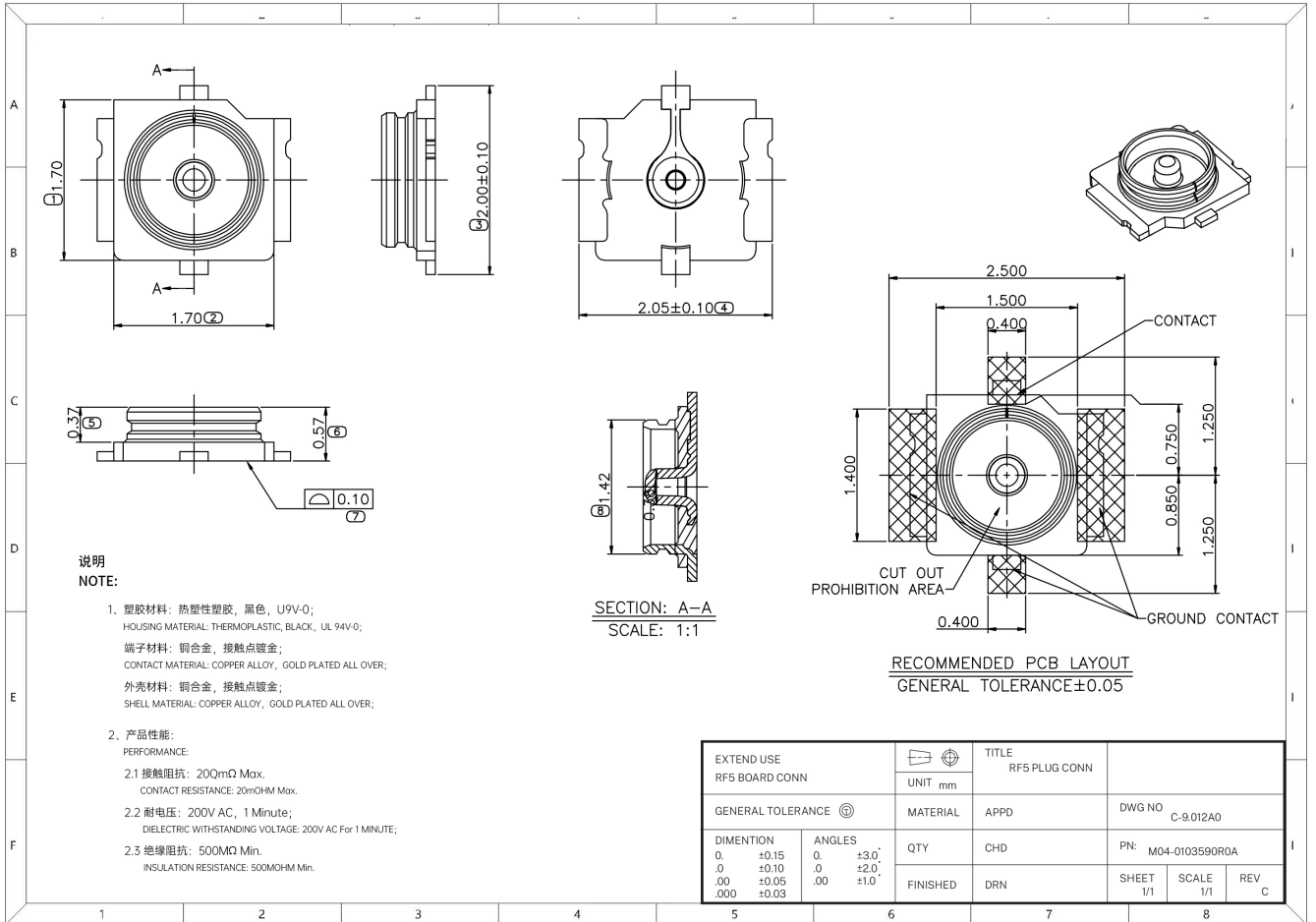

2. 适用范围 SCOPE

本技术规范适用于 RF 1.0H 连接器, 其中包括产品性能, 品质要求和测试方法

The specification covers performance, tests and quality requirements for RF 1.0H CONNECTOR.

3. 参考文件 APPLICABLE DOCUMENT

以下参考文件有 MIL-STD-202, EIA-364, UL-498, JIS C0020

The following documents form a part of this specification to the extent specified herein. In the event of conflict between the requirements of this specification and the product drawing, the product drawing shall take precedence. In the event of conflict between the requirements of this specification and the referenced documents, this specification shall take precedence.

MIL-STD-202, EIA-364, JIS C0020.

4. 产品构成/材料 CONSTRUCTION AND MATERIAL.

塑胶主体 HOUSING : 热塑性塑胶 (PLASTIC) ;

接触端子 CONTACT : 黄铜 (BRASS BRONZE)

外壳 SHELL : 磷青铜 (PHOSPHOR BRONZE)

5. 额定值 Ratings

A. 额定电压 Voltage Rating: 60VAC

B. 公称特性 Nominal characteristic impedance: 50Ω

C. 周波数 Frequency: DC0.1~6GHz

D. VSWR: PLUG 1.3Max.(DC0.1~3GHz),1.5Max.(3~6GHz)

Receptacle 1.3Max.(DC0.1~3GHz),1.4Max.(3~6GHz)

E. 使用温度范围 Service Temperature:233~363K(-40°C to 90°C)

6. 产品性能及测试要求和规范 PERFORMANCE, TEST REQUIREMENT AND PROCEDURES SUMMARY

6-1 试验条件 Test condition

温度 Temperature:288~308K(15°C to 35°C)

湿度 Humidity:45~75%RH

压力 Pressure:866hPa~1066hPa(650mm Hg~800mm Hg)

6-2. 产品性能及测试要求和规范 PERFORMANCE, TEST REQUIREMENT AND PROCEDURES SUMMARY

项目 ITEM	规格 STANDARD	测试规范 PROCEDURES
电性能 ELECTRICAL		
低功率接触阻抗 Low Level Contact Resistance	初值最大 20mΩ 20mΩ Max Initial 终值最大 40mΩ 40mΩ Max. Final.	公母端连接器配合后使用最大 20 mV 电压, 开路最大 10mA 电流进行测试. 参考 MIL-STD-202,Method 307 Mated connector, 20 mV Max. Open circuit at 10 mA Max. MIL-STD-202,Method 307
绝缘阻抗 Insulation Resistance	初期最小 500 MΩ 500 MΩ Min Initial 终期最小 100 MΩ 100 MΩ Min Final	使用直流电 100V, 保持 1 分钟, 测试端子与铜壳间. 参考 MIL-STD-202,Method 302 100V DC for 1 minute. Test between adjacent circuits and contact. MIL-STD-202,Method 302
耐电压 Dielectric withstanding Voltage	不能有电火花产生, 漏电流不能超过 2mA. No creeping discharge or flash over shall occur, Current leakage: 2mA Max.	使用交流 200V, 保持 1 分钟, 测试端子与外壳. 参考 MIL-STD-202 Method 301 100V AC 1 minute. Test between adjacent circuits and contact. MIL-STD-202 Method 301
VSWR	Plug 1.3 以下 0.1~3GHz,1.5 以下 3~6GHz Plug 1.3Max.at 0.1~3GHz, 1.5Max.at 3~6GHz Receptacle 1.3 以下 0.1~3GHz,1.4 以下 3~6GHz Receptacle 1.3Max.at 0.1~3GHz, 1.4Max.at 3~6GHz.	周波数:100M~6GHz Measure the VSWR as shown by the network analyzer.Frequency:100M~6GHz

机械性能 MECHANICAL		
拔去力 Un-mating force	<p>综合拔去力:初回拔去力 5N 以上, 30 回后拔去力 3N 以上</p> <p>Total un-mate force: Initial 5N Min. after 30 cycles 3N Min</p> <p>中心导体:初回拔去力 0.15N 以上, 30 回拔去力 0.1N 以上</p> <p>Un-mating force of inner contact: Initial 0.15N Min.after 30 cycles 0.1N Min.</p>	<p>插拔试验机以每分 25±3mm 的速度进行插拔</p> <p>Un-mate the receptacle connector(soldered to the test board)and plug at a speed 25±3mm/minutes along the mating by the push-on/pull-off machine</p>
引张强度 Crimp strength	<p>7N 以上</p> <p>7N MIN</p>	<p>通过引张试验机以每分 25+/-3 毫米/分钟的速度拉线材部分.</p> <p>Pull the cable as shown at a speed 25+/-3mm/minutes by tensile strength machine.</p>
耐插拔 Durability	<p>中心导体接触阻抗: 初期 20 mΩ, 以下, 试验后 40 mΩ 以下</p> <p>Contact resistance of inner contact initial 20 milli-ohm MAX. after testing 40milli-ohm MAX.</p> <p>外部导体接触阻抗: 初期 10 mΩ, 以下, 试验后 30 mΩ 以下</p> <p>Contact resistance of ground contact initial 10 mille-ohm MAX.after testing 30milli-ohm MAX.</p>	<p>母头连接器焊接在板上以每分钟 25±3mm 的速度插拔 30 次</p> <p>Mate and un-mate the receptacle connector (soldered to the test board)and plug 30 cycles at a speed 25±3mm/minutes along the mating by the push-on/pull-off machine.</p>

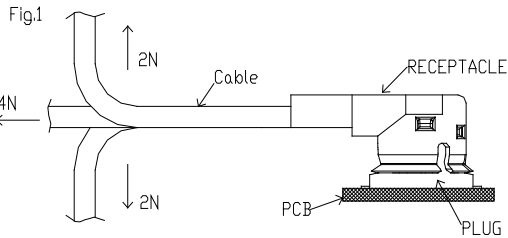
<p>保持力 Cable retention force</p>	<p>部品无外观及其它异常。 Appearance: Looseness between the parts, chipping, breakage or other abnormality shall not occur 试验中无 1 微秒的电流中断 Electrical discontinuity :No electrical discontinuity grater than 1 micro-sec. shall occur. 中心导体接触阻抗: 初期 20 mΩ, 以下, 试验后 40 mΩ 以下 Contact resistance of inner contact initial 20 milli-ohm MAX. after testing 40milli-ohm MAX. 外部导体接触阻抗: 初期 10 mΩ, 以下, 试验后 30 mΩ 以下 Contact resistance of ground contact initial 10 milli-ohm MAX. after testing 30milli-ohm MAX.</p>	<p>施加力于图 Fig.1 方向 Apply force on the cable as shown</p>  <p>试验期间工作电流 100mA DC, 检查瞬间电流中断。 During the testing, run 100mA DC to check electrical discontinuity.</p>
<p>振动 Vibration</p>	<p>外观无异常 Apply the following vibration to the mating connector. 试验中不得有超过 1 微秒的漏电流产生 Electrical discontinuity: No electrical discontinuity grater than 1micro-sec. shall occur. 中心导体接触阻抗: 初期 20 mΩ, 以下, 试验后 40mΩ 以下 Contact resistance of inner contact initial 20 milli-ohm MAX. after testing 40milli-ohm MAX. 外部导体接触阻抗: 初期 10 mΩ, 以下, 试验后 30 mΩ 以下 Contact resistance of ground contact initial 10 milli-ohm MAX. after testing 30milli-ohm MAX.</p>	<p>嵌合状态下振动, 试检中电流瞬断的确认。 Apply the following vibration to the mating connector. 周波数: 10Hz-100Hz-10Hz 约 15 分 Frequency: 10Hz-100Hz-10Hz/ approx 15 minutes. 片振幅, 加速度: 1.5mm or 59m/s²(6G) Half amplitude, peak value of acceleration: 1.5mm or 59m/s²(6G) 方向: 三个互相垂直的方向 5 次(约 75 分)实施。 Directions, cycle: 3 mutually perpendicular direction, 5 cycles(approx 75min) about each direction.</p>

<p>物理冲击 Physical shock</p>	<p>外观无异常 Appearanec:Looseness between the parts, chipping, breakage or other abnormality shall not occur. 不得有超过 1 微秒的漏电流产生. Electrical discontinuity: No electrical discontinuity grater than 1 micro-sec. shall occur. 中心导体接触阻抗:初期 20 mΩ 以下, 试验后 40 mΩ 以下. Contact resistance of inner contact initial 20 milli-ohm MAX. after testing 40milli-ohm MAX. 外部导体接触阻抗:初期 10 mΩ 以下, 试验后 30 mΩ 以下. Contact resistance of ground contact initial 10 milli-ohm MAX. after testing 30milli-ohm MAX.</p>	<p>嵌合状态在冲击试验机下冲击, 试验中 DC100mA 电流的瞬断确认。MIL-STD-202 试验法 203, 试验条件 B Apply the following vibration to the mating connector in accordance with MIL-STD-202, Method 213, Condition B. During the testing, run 100mA DC to check electrical 最大加速度: 735m/s²(75G) Peak value of acceleration: 735m/s²(75G). Duration: 11msec Wave Form: half sinusoidal Direpcndicular, 3 cycles about each direction.</p>
<p>环境性能 ENVIRONMENTAL</p>		
<p>盐雾腐蚀 Salt spray</p>	<p>外观无异常, 性能良好 Appearance no abnormality adversely affecting the performance shall occur 中心导体接触阻抗: 初期 20 mΩ, 以下, 试验后 40 mΩ 以下. Contact resistance of inner contact initial 20 milli-ohm MAX. after testing 40milli-ohm MAX. 外部导体接触阻抗: 初期 10 mΩ 以下, 试验后 30 mΩ 以下. Contact resistance of ground contact initial 10 mille-ohm MAX. after testing 30milli-ohm MAX</p>	<p>嵌合状态的连接器放置于以下条件 下: Apply the following environment to the mating connector in accordance with MIL-STD-202, Method 101, Condition B 温度: 308+/-2K(35+/-2°) Temperature: 308+/-2K(35+/-2°) 盐水浓度: 5+/-1%(重量比) Salt water density by weight: 5+/-1% 时间: 48 小时 Duration: 48 hours</p>

<p>高温寿命 Temperature Life</p>	<p>部品无外观及其它异常 Appearance: Looseness between the parts, chipping breakage or other abnormality shall not occur 中心导体接触阻抗: 初期 20 mΩ, 以下, 试验后 40 mΩ 以下 Contact resistance of inner contact initial 20 milli-ohm MAX.after testing 40milli-ohm MAX 外部导体接触阻抗:初期 10 mΩ 以下,试验后 30 mΩ 以下.. Contact resistance of ground contact initial 10 mille-ohm MAX.after testing 30milli-ohm MAX 绝缘阻抗:初期 500MΩ 以上,试验后 100MΩ 以上. Insulation resistance: initial 500 mega-ohm MIN.after testing 100 mega-ohm MIN.</p>	<p>嵌合状态的连接器放置以下环境 Apply the following environment to the mating connector in accordance 温度 363+/-2K(90+/-2°) Temperature:363+/-2K(90+/-2°) 时间:96 小时 Duration:96 hours</p>
----------------------------------	--	---

<p>热冲击 Thermal shock</p>	<p>部品无外观及其它异常</p> <p>Appearance: Looseness between the parts, chipping, breakage or other abnormality shall not occur.</p> <p>中心导体接触阻抗: 初期 20 mΩ, 以下, 试验后 40 mΩ 以下</p> <p>Contact resistance of inner contact initial 20 milli-ohm MAX.after testing 40milli-ohm MAX.</p> <p>外部导体接触阻抗: 初期 10 mΩ, 以下, 试验后 30 mΩ 以下</p> <p>Contact resistance of ground contact initial 10 mille-ohm MAX. after testing 30milli-ohm MAX</p> <p>绝缘阻抗:初期 500MΩ 以上,试验后 100MΩ 以上.</p> <p>Insulation resistance: initial 500 mega-ohm MIN.after testing 100 mega-ohm MIN.</p> <p>耐电压:沿面放电,空中放电,绝缘破坏无异常发生.</p> <p>D.W.Voltage:No creeping discharge,flashover,nor insulator breakdown shall occur</p>	<p>嵌合状态的连接器在以下环境</p> <p>Apply the following environment to the mating connector.</p> <p>温度, 持续时间:</p> <p>Temperature, duration:</p> <p>233K(40°)/30 分钟→</p> <p>278~308K(5~35°)/5 分以下→</p> <p>363K(90°)/30 分钟→</p> <p>278~308K(5~35°)/5 分以下</p> <p>233K(-40°)/30minutes→</p> <p>278~308(5~35°)K/minutes MAX.→</p> <p>363K(90°)/30minutes→</p> <p>278~308K/5minutes MAX</p> <p>实施 5 个循环</p> <p>No.of cycles:5 cycles</p>
------------------------------	---	--

<p>耐湿性 Humidity</p>	<p>部品无外观及其它异常</p> <p>Appearance: Looseness between the parts, chipping, breakage or other abnormality shall not occur.</p> <p>中心导体接触阻抗: 初期 20 mΩ, 以下, 试验后 40 mΩ 以下</p> <p>Contact resistance of inner contact initial 20 milli-ohm MAX.after testing 40milli-ohm MAX.</p> <p>外部导体接触阻抗: 初期 10 mΩ, 以下, 试验后 30 mΩ 以下</p> <p>Contact resistance of ground contact initial 10 mille-ohm MAX.after testing 30milli-ohm MAX</p> <p>绝缘阻抗:初期 500MΩ 以上,试验后 100MΩ 以上.</p> <p>Insulation resistance: initial 500 mega-ohm MIN.after testing 100 mega-ohm MIN.</p> <p>耐电压:沿面放电,空中放电,绝缘破坏无异常发生.</p> <p>D.W.Voltage:No creeping discharge,flashover,nor insulator breakdown shall occur</p>	<p>嵌合状态的连接器在以下环境放置.MIL-STD-202.试验法 103,条件 B</p> <p>Apply the following environment to the mating connector in accordance with MIL-STD-202,Method 103,Condition B.</p> <p>温度:313+/-2K(40+/-2°)</p> <p>Temperature:313+/-2K(40+/-2°)</p> <p>湿度:90~95%RH</p> <p>Humidity:90~95%RH</p> <p>时间:96 小时</p> <p>Duration:96 hours</p>
-------------------------	--	---

7. 产品认定和测试群组 PRPDUCT QUALIFICATION AND TEST SEQUENCE

Test of Examination	测试群组 Test Group													
	A	B	C	D	E	F	G	H	I	J	K	L	M	N
	测试序列 Test Sequence													
产品细查 Examination of product	1,3	1,3	1,5	1,3	1,5	1,5	1,7	1,7	1,5	1,5	1,5	1,3		
接触阻抗(低功率) Termination resistance (Low Level)			2,4		2,4	2,4	2,5	2,5	2,4	2,4	2,4			
绝缘阻抗 Insulation resistance							3,6	3,6						
耐电压 Dielectric withstanding voltage	2													
电压定在波比 V.S.W.R												2		
拔去力 Unmating force		2												
引张强度 Crimp strength											3			
耐久性 Durability			3											
保持力 Cable retention force				2										
振动 Vibration					3									
物理冲击 Physical shock						3								
盐水喷雾 Salt spray									3					
温度寿命 Temperature life										3				
热冲击 Thermal Shock							4							
耐湿性 Humidity								4						